



Optical Encoder Wiring Diagram

P/N 8767, P/N 8769

Wiring Diagram for the MASSO Optical Encoder

You won't need shielded cable as the encoder outputs high voltage signals for noise reduction. Please also note that the encoder can work directly with 24v, so you can simply wire the power connection and encoder signals on the DB9 pin on the wiring module.

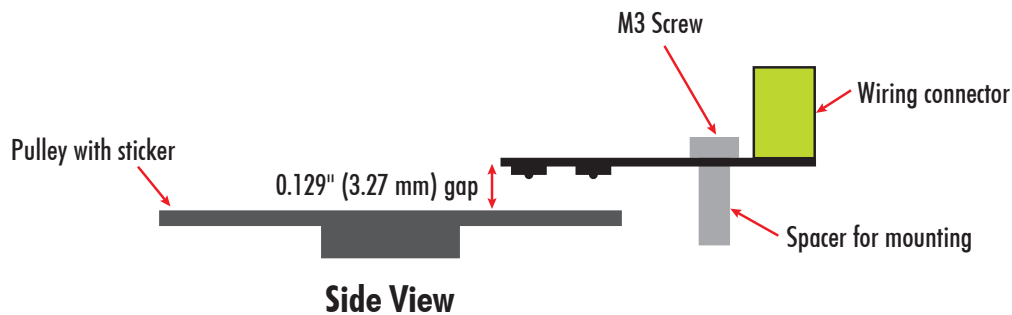

FIGURE 1—The Side View of the Optical Encoder shows the gap setting. M3 screws are equivalent to a 4-40 tap size.

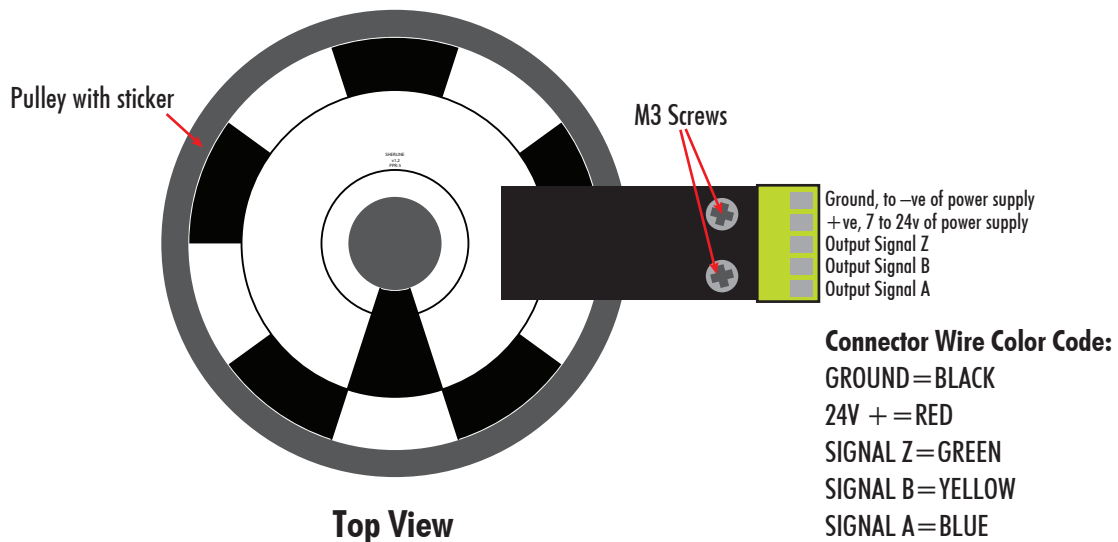

FIGURE 2—The Top View shows the wire connections and the wiring color code.

Thank you,
Sherline Products Inc.