



Sherline/MASSO Axis Connections and Axis Directions

Connecting the Power Cables to Your Machine

The accompanying images are to assist you in connecting the axis power cables to the corresponding stepper motor and to show the jog direction (+ or -) of each axis for the Sherline/MASSO CNC controller.

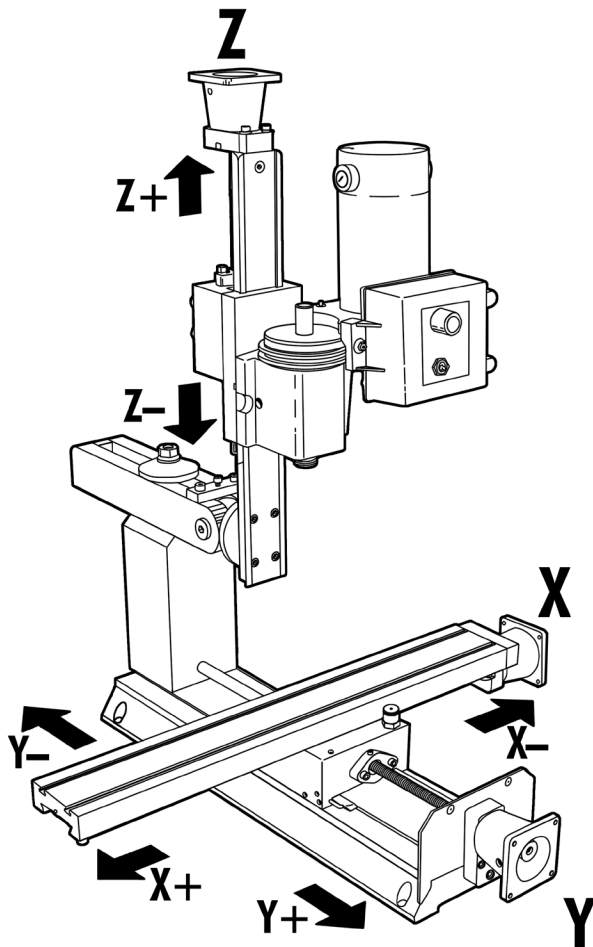

FIGURE 1—Mill

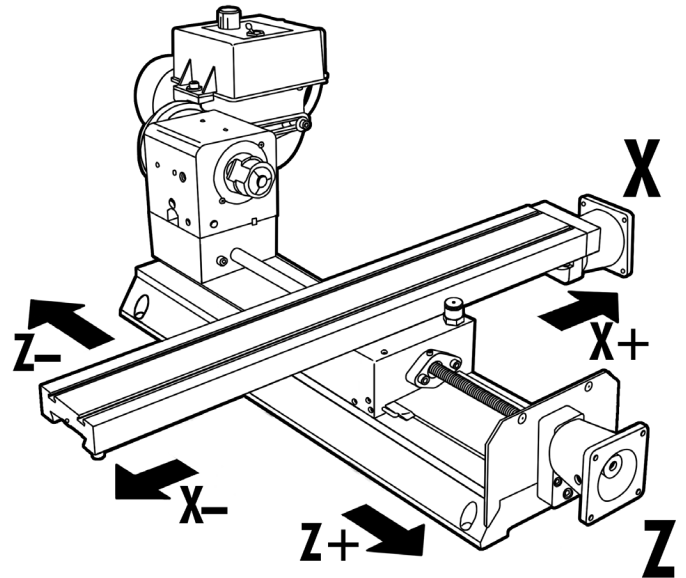

FIGURE 2—Chucker Lathe

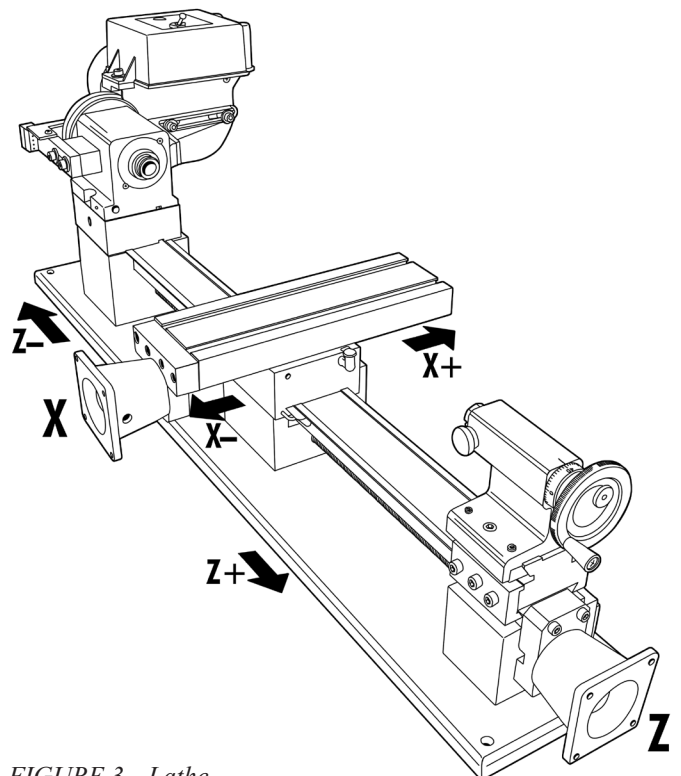

FIGURE 3—Lathe