

**SHERLINE
PRODUCTS**
INCORPORATED 1974

Headstock Riser Plate for 8" and 13" Crossslides

P/N 1294 (8"), P/N 1295 (13")

About the Headstock Riser Plate for 8" and 13" Crossslides

We designed the headstock riser plates at the request of several of our customers who replaced our 6" crossslide with the thicker 8" and 13" crossslides. Most of these customers are using our lathe as a chucker lathe with gang-tooling. The problem that they were facing is that we only make two tool posts that are shorter so they will be on center when you use the 8" crossslide or 13" mill table in place of the 6" crossslide. **NOTE:** We do not recommend using the 13" mill table as a crossslide.

P/N 1294 is for the 8" crossslide and P/N 1295 is for the 13" crossslide. The riser plates raise the headstock to match the additional .250" of the 8" crossslide and .270" of the 13" crossslide. Therefore, all of our standard tool posts will now be on centerline with the headstock.

Be advised that the tailstock will not align with the headstock when using this spacer. Therefore, you will not be able to turn parts between centers. Additionally, some of our other accessories, such as the thread cutting attachment P/N 3100, will also not work when you are using this spacer.

To use the riser plate, you must first do the following (see Figure 1 for details):

1. Remove the headstock from the lathe.
2. Remove both P/N 40510 10-32 screws so you can remove the lathe base from the lathe bed.
3. Once the lathe base is removed you will need to remove the P/N 40900 82 degree, 10-32 screw from the headstock end of the bed. This will allow you to remove P/N 40370 leadscrew support.
4. Pull the leadscrew support out.
5. Remove the P/N 40240 pivot pin.
6. Insert the new pivot pin P/N 12941 in place of the original pivot pin.
7. Slide the leadscrew support back into place (with the 5/8" diameter cutout facing down towards the lathe base). If you have the sliding shaft P/N 15090 and the fixed shaft P/N 15430 inside your leadscrew support, you will need to install them again. If you need help with this installation, read the instructions for the thread cutting attachment ([P/N 3100inst.pdf](#)).
8. Insert the 82° x 10-32 screw into the leadscrew support.

9. Mount the lathe bed onto the lathe base.

10. Insert the two P/N 40510 10-32 screws into the base.

SPECIAL NOTE: DO NOT OVERTIGHTEN these screws, or you will strip out the threads!

11. Mount the riser plate (P/N 12940 for the 8" crossslide or P/N 12951 for the 13" crossslide) onto the lathe bed using the headstock key P/N 40260. The headstock key that is in the bed will need to be pulled back a bit since the keyway slot length in the riser block is shorter. This means that your head key will stick out a bit more, but that is OK.

12. Mount your headstock onto the riser plate using the original head key.

You should be ready to start making chips.

Thank you,
Sherline Products Inc.

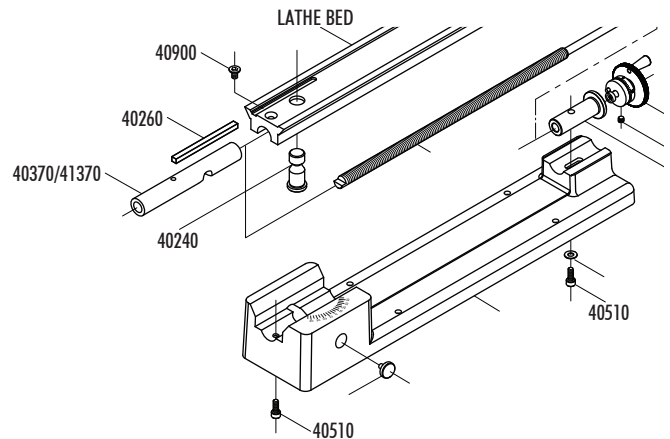

FIGURE 1— The exploded view is for part identification.

1294 and 1295 Parts List

NO. REQ.	PART NO.	DESCRIPTION
1	12940	Riser Plate for 8" Crossslide* (1294 only)
1	12951	Riser Plate for 13" Crossslide** (1295 only)
1	12941	Extended Pivot Pin
1	40260	Head Key

The material for the riser plate is anodized 6061 aluminum.

* 12940 Dimensions: .250" x 2.75" x 3.0" (H x W x D)

** 12951 Dimensions: .270" x 2.75" x 3.0" (H x W x D)