

CNC Mill Power Feed

P/N 8850

Installing and Using The Sherline Linear CNC Power Feed

By Bryan Mumford and Joe Martin

Using the Template blocks to locate new mounting holes for the stepper motor mounts

This kit contains a template block that will help you locate the holes needed to fit stepper motor mounts to your Sherline mill table (X-axis) or base (Y-axis). (Sherline machines manufactured after 9/99 have the stepper motor mount holes predrilled to make this job easier.) The rectangular template block is used to aid in drilling these holes on the mill. These blocks are not hardened, because they will only be used once or twice. To drill the holes for the stepper motor mount for each axis, follow the steps below:

- 1) Using the handwheels, move the table and saddle so that they are as close to the handwheel as possible.
- 2) On models with standard handwheels, break loose the 5-40 screw in the center of the face of the handwheel before removing the handwheel. The handwheel gives you a way to hold the leadscrew while breaking the center screw loose.
- 3) Remove the handwheel by loosening its set screw with a 3/32" hex wrench and pulling it off the shaft. (For

- adjustable "zero" handwheels, rotate the engraved red collar until the hole lines up with this set screw.)
- 4) Remove the leadscrew thrust from the table or base by removing the single 5-40 screw.
- 5) Remove the 5-40 screw from the end of the leadscrew being careful not to damage threads or shaft as you keep the screw from rotating.
- 6) Bolt the template parallel to the table or base with the 5-40 SHCS provided with the kit.
- 7) Using the holes in the template as a drill guide, start each hole about 1/16" deep with a #29 drill 0.136".
- 8) Remove the template block and drill each hole .25" deep backing the drill out to clear chips add cutting oil and finish drilling the hole in two more steps until a depth of 0.5" is reached. Countersinking the holes will make it easier to start a tap.
- 9) Tap the holes to 8-32 to 0.4" depth. Be sure to use cutting oil. Remember the part is relatively expensive to replace. Take your time. Remove any burrs from the surface of the part after tapping the hole.

INSTALLING THE STEPPER MOTOR MOUNT

- 1) Thread the preload nut onto the leadscrew.
- 2) Slide the stepper motor mount over the X- or Y-axis leadscrew end.
- 3) Push a coupler through the bearings and over the tapered end of the leadscrew. Attach it to the leadscrew with the new 5-40 screw provided. To tighten, put a hex key through the hole in the side of the mount and into the handwheel shaft set screw. Hold the key to keep the shaft from turning while tightening the 5-40 SHCS in the end of the coupling.
- 4) Using a 3/8" wrench, adjust the preload nut snugly against the end of the bearing. Tighten to remove all endplay. (See Figure 3 to understand how the nut preloads the bearings.) Turn the coupling by hand to make sure it turns freely, then put a little LocTite® on the threads behind the preload nut and let capillary action draw the fluid in. Figure 2 shows how to use a hex key through the hole in the mount to keep the coupler from turning while tightening the preload nut.

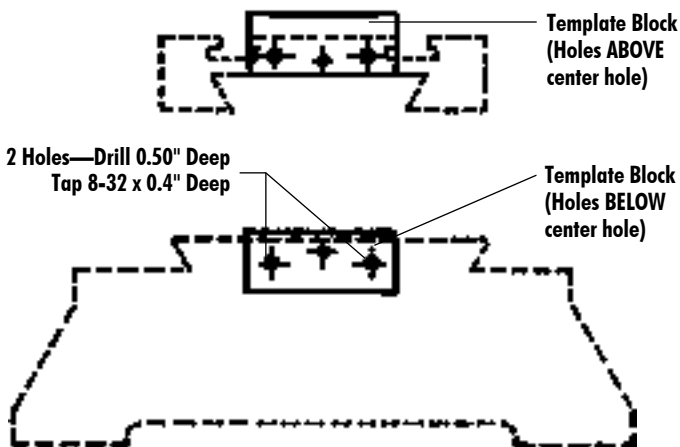

FIGURE 1—The rectangular block is used for the mill table and base. On the table, the two new drilled holes are ABOVE the existing center hole. On the base, the two new holes go BELOW the center hole as shown in the drawings above.

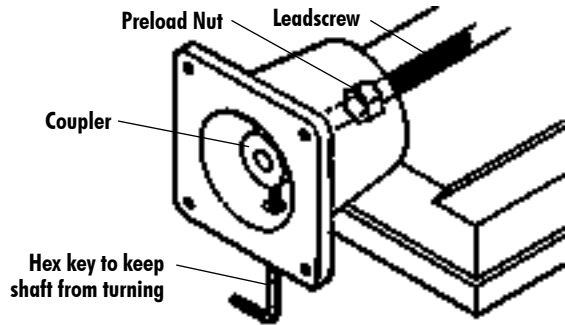

FIGURE 2—Using a hex key to keep the leadscrew from turning while tightening the 5-40 screw and preload nut.

5) With the leadscrew screwed into the mill saddle as far as practical and the table moved to its extreme left position, attach the stepper motor mount to the table by installing two 8-32 x 3/4" SHCS provided. This will assure proper alignment. The 8-32 socket head cap screws go inside the motor mount and thread into the tapped holes in the table. Before tightening the screws, turn the coupler by hand to make sure the mount is properly aligned and is not putting tension on the leadscrew. The holes in the mount are slightly oversized to allow for minor alignment adjustments. Check again for proper alignment by again hand turning the coupler to assure there is no binding after final tightening of the screws.

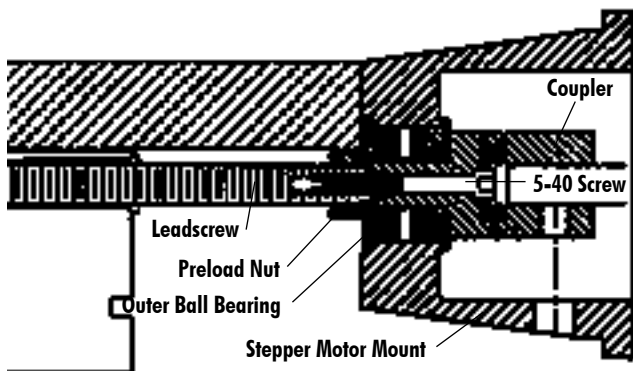

FIGURE 3—A cross-section of the stepper motor mount shows how the coupler is attached to the leadscrew.

Attaching a stepper motor to the mount

Push the shaft into the coupling and tighten the set screw, being sure that it is aligned with the flat. Attach the stepper motor to the mount using the three SHCS provided. The fourth hole can be used for a "cable tie" to secure the cable or a screw at your discretion. Attach the handwheel to the shaft to the other end of the stepper motor, aligning the set screw with the flat on the shaft.

Overview

Bryan Mumford, who designed the electronics and did the programming, and I have written the basic instructions for the computer. Even though the computer is small, it is a very complex device that both computes and drives the stepper motor in microsteps. Like all electronic devices, the easier it is to operate, the harder it was to design and program. These instructions are easy to read and shouldn't give you any problems, but if they do, please notify us at

Sherline, and we will attempt to improve them. We want our instructions to be the best in the business. The most important rule is to always work safely and accurately.

Power of the motor

The stepper motor is rated at over 100 oz-in of torque, with the highest power being achieved at low RPM (feed rates). The maximum speed of 25 Inches Per Minute (IPM), with a 0.050 leadscrew pitch, provides high speed but very little power. To use that setting for positioning, the system must be completely free from drag. We recommend using a maximum speed of 15 IPM as a positioning speed to avoid stalling the stepper motor. When cutting, a slow speed should be used to take advantage of the motor's power.

Positioning Accuracy

The first thing you have to understand about a CNC stepper motor powered machine slide is that its accuracy is determined by the leadscrew, not the stepper motor. The stepper motor takes 400 steps to make exactly one revolution. The motor drives the leadscrew with a 0.050 pitch. Twenty revolutions are needed to make the table move one inch. This means the final position will be within ± 1 step of the maximum error. This turns out to be a very small amount, approximately 0.0001". This can be considered less error than the leadscrew has. Sherline leadscrews are manufactured "in house" on a precision thread roller and have an error of less than 0.003" in 6". Rolled threads were chosen because they have excellent wear characteristics.

The importance of reading the instructions

It is impossible to make a product this complex "idiot proof". The best rule I've ever come up with when dealing with any type of CNC equipment is this: "You have to know what the unit will do after you push the button BEFORE you push the button." This can only be accomplished by reading the instructions and playing with the table drive without cutters or the possibility of a crash at the same time until you thoroughly understand how the features of this unit work. Again, don't have a cutter in the spindle until you truly understand how to operate it.

Precautions when turning the unit on and off

- As with any piece of electronic equipment, make sure the power is off before plugging the stepper motor connecting cord into the control unit.
- If a part has been aligned on the table and the power is switched off, the part should be realigned after turning the unit back on before continuing. Electrical "spikes" can cause the motor to move a few steps when turning it on. The power can be left on continuously for several hours without damage; however, the controller should be left in the [JOG] mode. Otherwise the motor may be left in an energized state. This may cause the motor and controller to heat up to an undesirable temperature over an extended period of time. Don't leave the unit turned on and unattended for long periods of time. If you turn it off, record the handwheel position so you can reconfirm the correct starting position when turning it back on.

Precautions regarding manual mode

When hand cranking the handwheel in the manual mode, the stepper motor acts as a generator. If you crank the handwheel rapidly, there is a chance that the control box electronics could be damaged by the current generated. If the unit is to be used extensively in the manual mode, it is recommended that you disconnect the cable from the motor to the controller.

Operating Instructions

The Sherline Table Controller is a self-contained, microprocessor-based controller that will automate the motion of the Sherline milling table without losing the option of manually moving the slide. The controller is designed to drive the table in precise, measured steps controlled by simple programs that you enter by using keys on the keypad.



FIGURE 4—Layout of the keypad.

Moving the table

There are three primary ways to drive the table:

- 1) Using the POSITIONING MODE you can specify the exact distance you want the table to move and the speed at which it moves. For example, if you enter 1.321", the table will move 1.321 inches at the programmed rate.
- 2) Using the PROGRAM MODE you can enter a series of programmed steps. For example, you can have the table move 1.500" at a rapid feed rate up to the work, then move at a slower programmed feed rate for 1.000" while making your cut, then reverse rotation and move 2.500" to a home position. You can enter up to 40 steps in each of two separate programs. You can also specify the feed rate for each step, and whether the table is to pause and wait after a step is taken or move continuously.
- 3) In the JOG MODE the controller will move the table to the left or to the right using the [1] or [3] buttons

on the keypad on the controller. Jog mode also allows the stepper motor to be turned manually.

General specifications

- Resolution of positioning is governed by the leadscrew. However, the stepper motor will stop within 1/400 of a revolution.
- The speed of the slide can be set from very slow rate of one inch per minute to a maximum of 25 inches per minute. Note that the higher speeds do not have much power and will only be used for positioning the table quickly, not for cutting operations.
- The controller uses "ramping" to accelerate and decelerate during each step. You can enter the minimum and maximum speeds used to suit your work. (The amount of ramping becomes noticeable when the slow feed is set below 10 IPM in the setting mode and the fast speed above 15 IPM.)
- The controller allows a programmable amount of backlash compensation.

Using the controller

The controller must be plugged into its AC adapter power supply. The power jack is located on the end of the unit. It is turned on with the toggle switch located next to the power jack. We wish that the power supply connector had a better locking system, but we had to use what was commercially available. With the power turned off, the motor cable must be plugged into the 5-pin DIN connector next to the power switch.

The basic operation of the controller is to press the [MODE] key to advance from one mode of operation to the next. This will cycle through the various modes of operation. When the mode you wish to use is displayed, press the [ENTER] key to start that mode and enter the parameters of operation. The three modes are:

- Positioning
- Program
- Settings

PANIC STOP—Any time the table is moving you can stop it immediately by hitting the [STOP] (Jog) key. This will stop all motion and put you into the JOG mode. Remember that the motor must be moving for the jog key to stop the program; therefore, hold it down long enough to be sure the program has been shut down. You will lose your place in the program you were running and will have to start over, but if you record the handwheel settings at home position before starting to run your program, this can be easily accomplished.

The "Positioning" mode

The Positioning Mode allows you to specify the exact amount you want the table to move. This amount of motion will occur each time that you signal the controller to advance. The resolution of the controller is .001 inches.

When the display reads "Sherline Linear Slide" press the [MODE] key once to advance to the Positioning Mode. The display will read:

Positioning Mode
Press Enter

To use the Positioning Mode, press the [ENTER] key. The display will read:

Inches: 00.000
Enter a number

You can now enter the distance you wish to travel. When you press a number key, that number will appear on the display where the cursor is blinking. To move the cursor left, press the [PRV] (Previous) key. To move the cursor right, press the [NXT] (Next) key or type any digit. The speed at which the table moves is controlled by the number of inches per minute entered in the “Fast” and “Slow” parameters of the Settings Mode.

You can also specify whether the table is to move left or right when you enter the amount you wish to move. Normal motion is to the right. To enter a table movement to the left, when viewed from the front of the machine, press the [MINUS] key. This will add a minus sign before the distance of move requested. When the move is entered as a negative value, the [NXT] key will move the table to the left. However, if you press the [PRV] key, the table will move to the right. To make a negative value positive, press the [MINUS] key again. (Standard CNC configurations have the + and – signs used in the same manner as an x-y coordinate grid.)

When the number you want is displayed, press [ENTER]. For example, suppose you typed “01.250” for the distance to move. After you hit [ENTER], the display will read:

01.250 00.000
Press Nxt or Prv

The first number is the movement and direction you selected (01.250 inches to the right). The second number is the current position (00.000 inches). The controller is waiting for you to press the [NXT] or [PRV] keys. If you press [NXT], the table will advance to the right 01.250", and the display will read:

01.250 01.250
Press Nxt or Prv

The current position is now shown to be 01.250". If you press [NXT] again, the display will read:

01.250 02.500
Press Nxt or Prv

The current position is now shown to be 02.500". If you had pressed the [PRV] key the first time, the table would move 01.250" to the left, and the display would read:

01.250 – 01.250
Press Nxt or Prv

The current step is shown to be 1.250" and the current position is minus 1.250".

PANIC STOP—Any time that the table is moving, you can stop it immediately by hitting the [STOP] (Jog) key. This will stop all motion and put you into the JOG mode.

You will lose your place in any program you were running and will have to start over.

To exit from the Positioning Mode, press the [MODE] key.

Note: To keep these instructions from becoming too cumbersome, we haven't listed every keystroke (such as [Enter]) from this point on. Use the choices listed on the controller display.

The “Program” mode

The Program Mode allows you to prepare a sequence of motions to take one after another. Each motion is called a “block”, and for each block you will enter four parameters:

- 1) The distance to move.
- 2) The direction of travel.
- 3) The feed rate for that move.
- 4) Whether or not the table should wait for you to hit the [NXT] key after each step is taken.

The program you enter will be remembered indefinitely (unless you change it), even if you turn the controller off. There is room for two separate programs of 40 blocks each.

Before you enter your program blocks, you'll want to plan them carefully to be sure they're correct before typing them all in. Write them down on paper and check for errors.

The Program Mode comes after the Positioning Mode. Press the [MODE] key until the screen says:

Program Mode
Press Enter

Then press the [ENTER] key. The display will read:

Which program?
Press 1 or 2...

You can now select which program you will use. Enter the digit “one” or “two” and the screen will display:

Program 1
Run = [NXT] Edit = [PRV]

This indicates which program you've selected, and that you should press the [NXT] key to run the program that was stored previously, or press the [PRV] key to enter a new program or edit the existing one.

Entering a new program

Press the [PRV] key and the display will show the first program step.

For example, the display may read:

Block 1:1
Inches: 01.500

The “1:1” means you're working on program 1, block number 1. A block is considered as the complete set of instructions for a programmed instruction. The first instruction in this example is to move the table 01.500" to the right (left movement would have had a minus sign

displayed). Edit this number if necessary and press the [ENTER] key.

The display may then read:

Block 1:1
Feed rate: 5

This means that the feed rate for this programmed move is 5 inches per minute. The number you enter will be the fastest rate the table will reach during a move. Edit this number if necessary and press the [ENTER] key.

The display will read:

Block 1:1
Pause (or No Pause)

Ending a block with “Pause” means you must hit the [NXT] key during program execution before it will advance. Ending a block with “No Pause” means that the program will advance to the next block without stopping. Press the [7] key to enter “Pause” or the [9] key for “No Pause.” (Pressing the [8] key will enter a “Stop” command. Its use is described later in “Linking Controllers.”)

After entering the PAUSE parameter the display will read:

Block 1:2
Inches: 00.000

This indicates that you’re ready to program the movement for block 2 in program #1. You can now define the step size, feed rate, and pause status just as you did for the first block.

When you’ve entered all of the program blocks you wish, terminate the program by entering “00.000” for the amount of travel. This tells the controller to stop asking for new input. After this, you will be able to run the program you’ve just entered. Remember that the program you write should have the total distance programmed equal to zero when all motions are added together. This will insure that you return to your home position. However, it would be wise to check the handwheel position to verify this.

Insert and Delete

When entering a program, you may make a mistake and wish to omit a block after the entire program has been written. You can INSERT and DELETE complete blocks to correct or modify an existing program. Without this feature you would have to rewrite all the blocks after the error. To access the INSERT and DELETE functions, press the [MODE] key while the controller is waiting for you to enter the distance for any program step. (You can’t use INSERT or DELETE after entering the distance). When you press the [MODE] key, the controller will cycle through four choices: “Start Loop”, “Insert”, “Delete”, and “Exit”. The “Start Loop” command will be explained later in these instructions.

When the display is at the “Insert” point it may say:

Block 1:5
Insert?

You can now insert a new block by pressing the [ENTER] key. If you wish to delete the current block, press the [MODE] key again and then [ENTER]. Press the [MODE] key a third time and the controller says “Exit?”. If you press [ENTER] here, you will terminate the programming session entirely. To return to the program block that is already stored without making any changes, press the [MODE] key a fourth time.

The loop command

If you press the [MODE] key at the very start of a new block the display will read

Block 1:1
Begin Loop?

This means that the instructions entered from this point to the point that an “End Loop” is entered, in the same manner, will be repeated for as many times as entered after entering the command “End Loop.” The “End Loop” can only be entered after a “Begin Loop” has been entered. It is acceptable to have a “Pause” command entered in the loop program. This would require you to press [NXT] for each stage of the loop; however, keep track of the loops made. (The lower right corner of the display displays how many times the loop has left to cycle.) You could inadvertently start into another set of loops by pressing the [NXT] key one time too many. Remember that the only time you will be offered the loop command choice is when the mode key is pressed before entering a movement number.

The LOOP COMMAND allows you to easily program a series of identical movements.

Running a stored program

Enter the Program Mode using the [MODE] key and press the [ENTER] key. You now have a choice of program 1 or 2. Enter your choice using the [1] or [2] key. Then press the [NXT] key to run the program. The program will start. While the table is in motion, the display will read:

Moving...

Controlling the program while it is running with the Stop, Mode and Pause commands

The [8] key can be entered anytime a program is running, with or without loops and put the program in a “Pause” mode. The program will stop running after the computer completes the block it was running when the command was entered; however the key must be held down until the program ends its present movement. The program can be restarted with the [NXT] key and will resume running the program from its last completed command.

You can terminate execution at any time by pressing the [MODE] key, which will allow you to go back and enter a new program or start running the same one over again. Again, the key must be held down until the move for that block was completed.

You can press the [STOP] key at any time to abort table motion and it will enter you into the Jog Mode. Remember that you will lose your place and have to manually move to your home position before running your program.

Restarting the program

After all of the steps in the program are completed, the program will stop and wait for you to hit the [NXT] key if you stored a “Pause” at the end. If you stored “No Pause”, the program will start over again immediately.

NOTE: If the controller seems to refuse to run a program, it is probably because the first movement in the program has been defined as “000.000” degrees. If this happens, go to EDIT and check the program has been edited to zero.

Old programs can be erased by holding down the [9] when the controller is turned off and turning it on. We recommend doing this occasionally so you can start with a “clean slate.”

The “Settings” mode

The next mode after the Program Mode is the Settings Mode. This allows you to enter some parameters of operation for the controller. The controller will remember these settings. You have a choice of Slow, Fast, Direction and Backlash. You should be familiar enough with the controller by now to make these entries without step-by-step instructions.

Slow setting

This is the speed with which the table starts each movement. The units are inches per minute, and may range from 1 IPM to 15 IPM. 15 IPM is the fastest speed you may enter. The table can’t reliably start movements without ramping up from a slow speed and 15 can only be used in a no-load condition. Whenever the table moves, it starts at the SLOW feed rate and ramps up to the FAST feed rate. It also ramps down to the SLOW rate before stopping.

Fast setting

This is the maximum speed the table reaches in each movement. The units are always in inches per minute, and may range from 1 to 25. If you set the FAST rate the same as the SLOW rate, the rate of motion will be constant during the move. The table does not have as much power at the fastest settings, so very fast settings should only be used for positioning. If you set the FAST value lower than the SLOW value, the setting for SLOW will be changed to match what you entered for FAST.

Direction setting

This parameter allows you to enter the default direction of travel. The default setting of “3” assumes that the controller will be driving a RH leadscrew on the X axis of a Sherline mill, and positive values will move the table to the right. If the controller is used to control a different device, a setting of “1” may keep programming standards conventional.

Setting the electronic backlash compensation

The physical backlash in the leadscrew can be minimized with proper adjustment; however, it cannot be eliminated. The controller supports automatic backlash correction to compensate for whatever actual backlash remains between the nut and leadscrew. You can enter a two-digit number. The number entered represents steps of the stepper motor. The motor takes 400 steps to make one

revolution. Therefore, 8 steps on a Sherline mill equal 0.001 inches of travel.

It works in this way: Every time the table makes a motion in the “reverse” direction, it will overshoot the amount of travel by the backlash amount, and then move “forward” by the same amount. This will take up any backlash. You can set the backlash correction to any amount you like. If you set it to zero, it will not be used. If you set it to a small amount, it can just exactly take up the backlash in the leadscrew. If you set it to a relatively large value, you can see the table overshoot and then return to correct position.

You can determine how much backlash to use by trial and error and your own preference. To evaluate the current backlash setting, go to the Positioning Mode. Enter something like 00.500 inches. Press the [PRV] key. The table will move in the reverse direction and overshoot the distance specified by the backlash amount, then change direction and move forward by the backlash amount. If the backlash setting is small, you won’t notice it. If it is large, it will be easy to see.

The “Jog” mode

The Jog Mode allows you to quickly move the table with the keypad. In Jog Mode, with no keys held down, the motor is unpowered. This means you can turn the crank by hand for fine positioning. You can drive the table using the [1] or [3] keys for rapid, motorized motion. The [7] and [9] keys will move the table at the “Slow” speed set in the SETTINGS Mode. You can also take very fine, slow steps with the [NXT] and the [PRV] keys. When you are finished with the Jog Mode, press the [MODE] key until the controller is in the Mode of your choice.

Remote trigger switch

The controller can be operated from a remote switch. This will allow you to keep the controller in a more “friendly” environment and have a more durable switch used for starting a programmed sequence. To incorporate this feature, connect the remote trigger switch that is normally open to the SENSE INPUT and GROUND (OUTER RING) wires of the included 8-pin connector cord. Refer to Figure 5 below. (NOTE: The first time a program is run, it must be initiated by hitting the [NXT] button on the keyboard. After that, it can be initiated from the remote switch.)

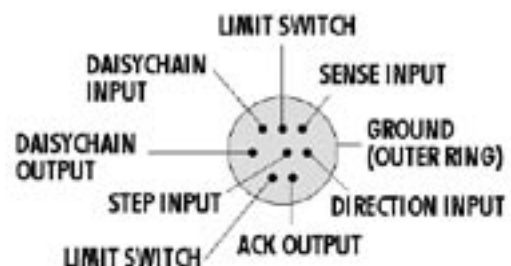

FIGURE 5—Layout of the interface male connector viewed from the back side

Cable color code

Colors of the wires inside the cable are not consistent from batch to batch, so we cannot provide a reliable color

code. Use a continuity checker and the pin map shown in Figure 5 to determine the color of the wire connected to each pin. Note the colors on the chart in Figure 5 for future reference.

Limit switches

The Sherline Linear Power Feed supports the use of limit switches to avoid running a cutter into a fixture or clamp. The limit switches should be simple “normally open momentary contact” type switches. You can place a limit switch at each end of the mill table if you wire them in parallel. Arrange the switches so they will be closed by the motion of the table when it gets too close to something you don’t want it to reach. The limit switches are wired into the 8-pin interface connector at the end of the controller. (See Figure 5.)

The limit switches will be active in all motion modes, including the JOG mode. When the controller moves into a limit switch, it will remember that it cannot move any farther in that direction. The controller will consider the move complete. Any further commands to move in that direction will also “pretend” to execute, but no actual motion will take place. Instructions to move in the opposite direction will work fine.

This feature will allow you to start a programmed move from a known position with the use of a quality limit switch. The program could drive the slide to the limit switch at a slow feed and then start its next move from where the limit switch stopped the movement of the slide. You could program the last move to end against the limit switch but in doing so you would lose the advantage of knowing that the program will always start from the same place. Be sure the move to the limit switch will have enough extra travel to compensate in case an operator moved the hand wheels between cycles.

To incorporate this feature, connect the limit switches that have been wired in the “normally open” position to the two pins of the included 8-pin connector cord noted as “LIMIT SWITCH” in Figure 5.

Once the controller has moved away from the limit switch, commands to move in that direction will again be honored.

Start-up commands

There are several utility commands that can be issued by holding down certain keys when the controller is first turned on. For example, to enter the SLAVE MODE (to run the controller with STEP and DIRECTION signals from another CNC controller) hold down the [1] key when you first turn the controller on.

The four start-up commands are:

- [1] - Enter “Slave” mode.
- [7] - Show the revision date of the firmware.
- [9] - Erase all program memory locations.
- [MODE] - Erase all program memory locations and initialize all settings to factory defaults.

Interface options

The following features were incorporated into the controller, primarily to allow the Sherline CNC rotary table to be used with standard CNC machines. They probably will not be used with a linear slide; however, the code has been written and may be useful in a way in which I have not yet anticipated.

There are two interface options for the controller. They both use the 8-pin mini-DIN connector at the top end of the controller case. The interface options are:

- “Step” and “direction” signals for use with other motor controllers.
- “Sense” and “acknowledge” signals for handshaking with other CNC controllers.

Step and direction input

If you have a motor controller that outputs STEP and DIRECTION signals for a fourth axis, you can use the Sherline controller to receive these signals and move the table. You’ll need a cable to connect the STEP and DIRECTION signals of your other controller to the proper pins of the interface connector on the end of the Sherline controller.

You must put the Sherline controller into a special “Slave Mode” to work with these signals. To do this, hold down the [1] key on the keypad when you first turn on the controller. The display should read:

Slave Mode

In this mode, the controller will wait for a low-going STEP command. As soon as it is found, the motor will move a single step in the forward direction if the DIRECTION input is high. If the DIRECTION input is low, the table will move a single step in the opposite direction. There are 400 steps in a full rotation of the stepper motor. To stop using the slave mode, turn the controller off, wait 5 seconds, and turn it on again.

Sense and acknowledge input

Some CNC controllers support a SENSE and ACKNOWLEDGE (ACK) protocol for a fourth axis with an “M” command. When the “M” command is executed, the controller closes a relay and then waits for the “M-FIN” input line to go high (open circuit) while the remote device is operating. When the remote device has finished, it must short the M-FIN line to ground to acknowledge that the action is complete.

The Sherline controller supports this M protocol. There is a SENSE input line and an ACK output line in the interface connector. The SENSE input is made active by shorting it to ground. It is left inactive by leaving it unconnected to ground, or by pulling it to 5 volts. The ACK output is an “open collector” drive signal. It can be used like a switch closure. When it is active, it will be connected to ground. When inactive, it will be an open circuit. The ACK output will work with signals as high as 30 volts.

The SENSE input works just like the [NXT] key on the controller. In either of the motion modes (Positioning or

Program) where you can move the table by pressing the [NXT] key on the keypad, you can also move the table by shorting the SENSE input to ground. You can use some other CNC controller to make the SENSE input low (for example, the M command}.

To connect your CNC controller to the Sherline controller, add a relay to your CNC machine. Connect the relay switch contacts to the Sherline controller SENSE and GROUND lines. When your controller closes the relay, it will trigger the Sherline controller.

Every time the [NXT] key or the SENSE input initiate a motion, the ACK output of the Sherline controller will be shorted to ground. As soon as the Sherline controller has completed the motion, the ACK output will be opened (will not be shorted to ground).

Linking two Sherline controllers together

The Sherline stepper motor controller has a unique feature that allows two controllers to be linked together and perform simple programs in unison. This allows the controllers to perform operations that are much more complex than what a single controller can do. They are linked together with an optional cord plugged into the back of each unit. It would be difficult to describe the many combinations that could be generated using this method, so I'll give you a general "overview" of the rules and leave the rest up to your imagination.

- 1) The Master controller that initiates the sequence may be in any motion mode. Note: the controllers may be either a linear or rotary type or a combination of both. The difference between the two is they each have code written specifically to control a linear slide or a rotary table.
- 2) The second controller (called the "Controllee") will start its program when the Master program comes to a block that is terminated with a "Pause" command or, if it's a rotary controller, it has completed a Division Mode or Degree Mode movement.
- 3) The Master will be restarted when the Controllee program comes to a block that is terminated with a "Pause" command, or, if it's a rotary controller, it has completed a Division Mode or Degree Mode movement.
- 4) When a programmed block is terminated with the "Stop" command (entered with the [8] key at the end of a program block), the program will stop and not trigger the other controller. The operator must press [NXT] to continue. It would be advisable to enter just one "Stop Command", and for it to be in a block in the Master controller. This keeps the operator from having to press [NXT] on both controllers to run a program.

Cutting a gear using all the features of both linear and rotary Sherline controllers

Example:

The following procedure gives you an idea of how easy it would be to program a complex set of operations to

produce a 53-tooth gear. I chose 53 teeth because it is a prime number and can't be produced with simple indexing.

Linear Controller Program:

- 1) Rapid feed up to gear blank from home position. No Pause
- 2) Slow feed across gear face with cutter. No Pause
- 3) Slow feed back across gear face for quality finish. No Pause
- 4) Rapid feed to home position. Pause

Sherline CNC Rotary Table Controller Program:

- 1) Using the Division Mode, enter the number 53

With five lines of code (keypad entries) you have now entered all the information needed to produce a 53-tooth gear. Think about it. The slide will rapid up to the cutter, slow down and make a cut, feed back across the part at a programmed feed rate, and rapidly return to its home position. The rotary table will then index, and initiate the next cut. This will be repeated until the required 53 indexes have been made. After the last index, the program will stop and wait for an operator. This has been accomplished inexpensively with a very clever design and program, and we at Sherline and Bryan and I are quite proud of it.

Two Linear controllers could be linked to produce any number of sequences for simple but useful movements. For example, one controller could drive the mill table X-axis, and the other could drill with the Z-axis.

Thanks for your support

We at Sherline wish to thank our customers for their continued support. It is becoming very difficult to compete in a world market where employers in the US pay more in benefits each month than the entire wage paid to workers in third world countries. We survive by having modern equipment and facilities with skilled workers who care about our customers and product line. We believe it shows, and it is our way of thanking you.

— Joe Martin, President and owner
Sherline Products Inc.

Technical assistance

For technical assistance regarding the mechanical portions of this product, please call Sherline Products Inc. at (760) 727-5857, fax (760) 727-7857 or e-mail craig@sherline.com. For technical assistance regarding the electronic portion of this product, please contact Bryan Mumford and the following address:

Bryan Mumford, Mumford Micro Systems
3933 Antone Road, Santa Barbara, CA 93110
Phone: (805) 687-5116
Fax: (805) 687-4905
bryan@bmumford.com
<http://www.bmumford.com>

PARTS LIST

- 40050 Handwheel assembly
- 40520 10-32 x 3/16" cup point set screw (2)
- 67100 8-32 x 3/8" SHCS (4)
- 67101 Stepper motor mount (X-axis)
- 67105 Coupler
- 67106 Preload nut (RH)
- 67111 8-32 x 3/4" SHCS (4)
- 67115 5-40 x 7/8" SHCS
- 67116 Template bushing (rectangular)
- 67120 Bearing (2)
- 67130 100 oz-in, 2 amp stepper motor
- 87041 120 VAC power supply (24 VDC, 1 amp output)
- 87250 Stepper motor-to-control box 6' extension cable
- 87350 Single 5-pin mini-DIN limit switch cable or 1/2 of daisy-chain cable
- 88100 Linear controller/keypad unit complete

SHERLINE INDUSTRIAL PRODUCTS DIVISION

Sherline has now introduced a line of small machine slides and spindles for use in industrial and production line applications. Based on components of the Sherline lathe and mill, these slides can be assembled in "building block" fashion to make a wide variety of movements possible. Special tooling can be built up quickly and at a very low cost as long as the size is appropriate. Manual and CNC-ready components are available. With the use of stand-alone CNC controllers like this P/N 8850 power feed, tooling can be assembled and on the job in a matter of hours, not days. For details, see: www.sherlineIPD.com

(Copy this page and save it as a master for future program records.)

